



EZR and IZR Installation Instructions

EZR (external reducers) adapt an external tee or union or the Parker and Swagelok® type fittings commonly used on injectors and detectors to Valco zero dead volume connections.

IZRs (internal reducers) are most commonly used for adapting small transfer lines to Valco valves with larger fittings.

External Reducers (EZRs)

1. Remove the plastic cap from the fitting assembly.
2. Remove the zero volume nut and the smaller ferrule from the EZR body. (**Figure 1**)
3. Slide the nut and ferrule onto the tubing, oriented as in **Figure 1**. Do not screw the nut into the EZR body yet.
4. Insert the tubing into the EZR body (with the nut and ferrule moving freely on the tubing) until it sits in the tubing seat in the insert.
5. With the larger ferrule over the insert, screw the EZR body onto the existing Parker or Swagelok fitting, but do not tighten anything.
6. While pushing firmly on the tubing so that the insert is all the way into the tubing seat in the Parker or Swagelok fitting, use a wrench to tighten the EZR body so that the larger ferrule will make up on the insert. (Approximately 1/3 turn past finger tight.)

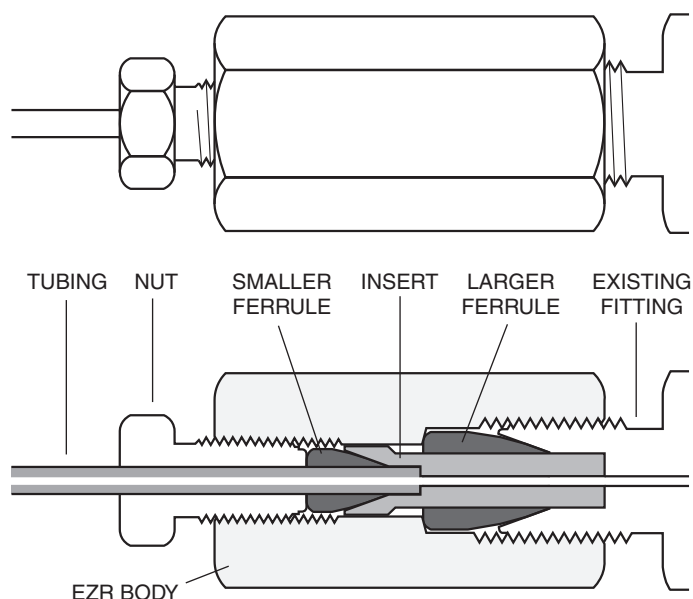

Figure 1: EZR cutaway view

7. Still pushing firmly on the tubing so that it is fully seated in the insert, tighten the zero volume nut into the EZR body to make up the smaller ferrule on the tubing. (Approximately 1/4 turn past finger tight.)
8. Check for leaks and tighten as necessary.

Swagelok® is a registered trademark of the Crawford Fitting Company

Internal Reducers (IZRs)

IZRs are shipped pre-assembled to make sure that all the necessary components are included. Follow these instructions to establish leak-free performance at run pressures up to 10,000 psi.

NOTE: For 360 micron fittings, refer to Technical Note 509 for additional information.

1. Remove the secondary nut and ferrule from the IZR body. (**Figure 2**)
2. Screw the IZR body with the liner and primary ferrule into the fitting detail, and fingertighten it.
3. Insert the tubing (that will later pass through the secondary nut and ferrule) into the IZR body, and push firmly to make sure that the liner is seated in the bottom of the detail.
4. While continuing to push firmly to keep the liner seated, use a wrench to tighten the IZR body 1/3 of a turn, causing the primary ferrule to make up on the liner.
5. Slide the secondary nut and ferrule onto the tubing as oriented in **Figure 2**.
6. Insert the tubing/nut/ferrule assembly into the IZR body and screw it in fingertight.
7. While pushing firmly on the tubing to make sure that it is bottomed out in the detail of the liner, tighten the secondary nut 1/3 turn.

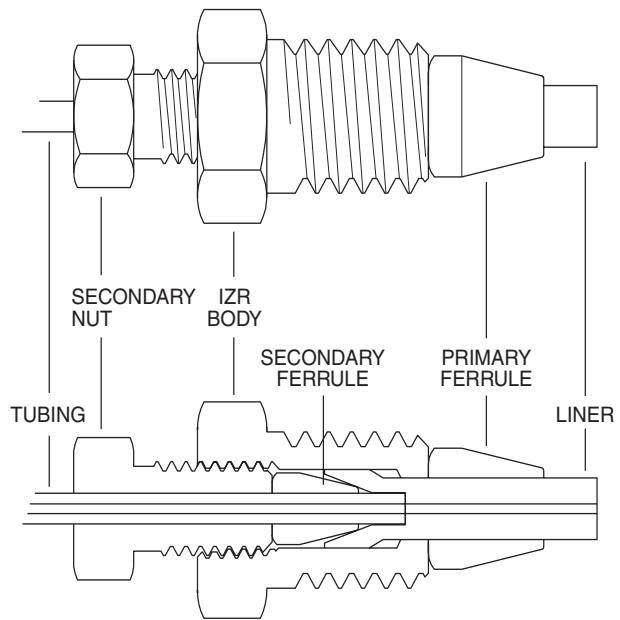

Figure 2: IZR cutaway view

Removing an IZR

If it's necessary to remove the IZR, remove the secondary nut, ferrule, and tubing before removing the IZR body, liner, and primary ferrule.

Reinstalling an IZR

To remake a previously tightened assembly:

1. Reinsert the IZR body, primary ferrule, and liner into the fitting detail, and fingertighten the body.
2. Use a wrench to tighten the IZR body 1/8 turn.
3. Reinsert the secondary nut, ferrule, and tubing into the IZR body, and screw the nut in fingertight.
4. Use a wrench to tighten the secondary nut 1/8 turn.

CAUTION:

Failure to tighten in this order will cause deformation of the liner and leakage at the primary ferrule.

North America, South America, and Australia/Oceania contact:

VICI Valco Instruments Co. Inc.
P.O. Box 55603
Houston, TX 77255
Sales: (800) 367-8424
Tech: (713) 688-9345
Fax: (713) 688-8106 valco@vici.com

Europe, Asia, and Africa contact:

VICI VICI AG International
Parkstrasse 2
CH-6214 Schenkon
Switzerland
Phone: +41 41 925 6200
Fax: +41 41 925 6201 info@vici.ch

Cheminert® and VICI® are registered trademarks of Valco Instruments Co. Inc. and VICI AG

TN-504 Rev 6/14