



**Valco Instruments Co. Inc.**

**Pulsed Discharge  
Detector  
Model D-4-I  
Instruction Manual**

Rev 1/15

---

*North America, South America, and Australia/Oceania contact:*  
**VICI Valco Instruments Co. Inc.**  
800 · 367 · 8424 sales  
713 · 688 · 9345 tech  
713 · 688 · 8106 fax  
valco@vici.com

*Europe, Asia, and Africa contact::*  
**VICI VICI AG International**  
Schenkton, Switzerland  
Int + 41 · 41 · 925 · 6200 phone  
Int + 41 · 41 · 925 · 6201 fax  
info@vici.ch

This page intentionally left blank for printing purposes

# Table of Contents

---

Introduction	
Description and Operating Principles.....	1
Safety Notes and Information.....	2
Symbols .....	2
Installation Category .....	3
Safety .....	3
Maintenance.....	3
Components of the Detector System .....	4
Description of Controls.....	4
Specifications .....	8
System Requirements.....	9
Components not Included with the Detector System .....	9
System Purity.....	9
Gas Specifications .....	10
Installation	
General Precautions .....	11
Mounting the Detector on the GC .....	11
Gas Connections.....	11
Installing and Purging the Gas Regulator .....	12
Installing and Purging the Helium Purifier.....	13
Connecting the Discharge Gas to the Detector.....	13
Capillary Column Connection .....	14
Packed Column Connection.....	14
Testing for Leaks .....	15
Electrical Connections .....	16
Initial Power-Up .....	17
Troubleshooting High Background Current .....	17
Checking for Leaks in the Discharge Gas Plumbing.....	18
Column Bakeout Precautions.....	18
Mode Selection and Setup	
Helium Ionization Mode.....	19
Selective Photoionization Mode .....	19
Warranty .....	21

This page intentionally left blank for printing purposes

# Introduction

## Description and Operating Principle

The PD-D-4-I is a non-radioactive pulsed discharge ionization detector (PDID), designed as a universal retrofit to existing GCs. A schematic representation of the basic D4 detector is shown in **Figure 1**.

The D4 utilizes a stable, low power, pulsed DC discharge in helium as the ionization source. Elutants from the column, flowing counter to the flow of helium from the discharge zone, are ionized by photons from the helium discharge above. Resulting electrons are focused toward the collector electrode by the two bias electrodes.

The principal mode of ionization is photoionization by radiation arising from the transition of diatomic helium  $\text{He}_2(A^1\Sigma_u^+)$  to the dissociative  $2\text{He}(1S^1)$  ground state. This is the well-known Hopfield emission. The photon energy from the  $\text{He}_2$  continuum is in the range of 13.5 eV to 17.7 eV.

The D4 is essentially non-destructive (0.01 - 0.1% ionization) and highly sensitive. The response to organic compounds is linear over five orders of magnitude with minimum detectable quantities (MDQs) in the low picogram range. The response to fixed gases is positive (the standing current increases), with MDQs in the low ppb range.

Detector response is universal except for neon, which has an ionization potential of 21.56 eV. Since this potential is close to the energy of the  $\text{He}^*$  metastable (19.8 eV) but greater than the photon energy from the  $\text{He}_2$  continuum, neon exhibits a low ionization efficiency and low detector response.

When a dopant is added to the discharge gas, the D4 also functions as a selective photoionization detector. (Suitable dopants include Ar for organic compounds, Kr for unsaturated compounds, or Xe for polynuclear aromatics.)

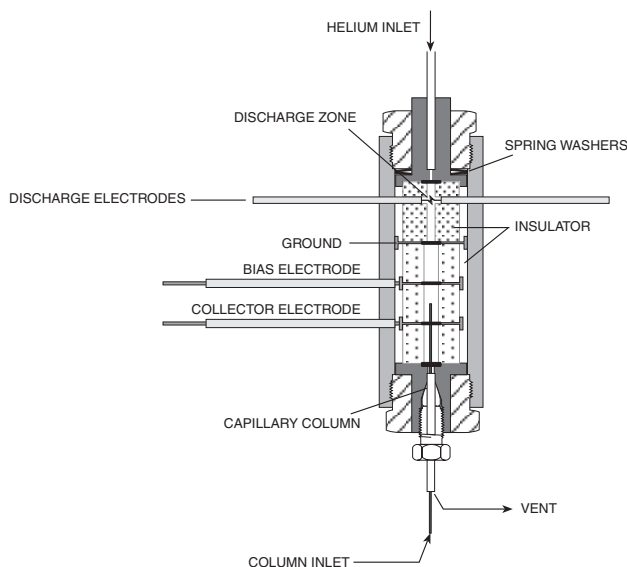

**Figure 1:** Schematic of the D4 detector

### Helium Ionization (PDHID)

The PDHID is essentially non-destructive (0.01 - 0.1% ionization) and highly sensitive. The response to organic compounds is linear over five orders of magnitude with minimum detectable quantities (MDQs) in the low or sub picogram range. The response to fixed gases is positive (the standing current increases), with MDQs in the low ppb range.

The PDHID response is universal except for neon, which has an ionization potential of 21.56 eV. Since this potential is close to the energy of the He\* metastable (19.8 eV) but greater than the photon energy from the He<sub>2</sub> continuum, neon exhibits a low ionization efficiency and low detector response.

### Photoionization (PDPID)

Changing the discharge gas from pure helium to helium doped with argon, krypton, or xenon changes the discharge emission profile, resulting in resonance atomic and diatomic emissions of the rare gas added. Response is limited to sample compounds with ionization potentials less than or equal to the dopant gas emission energy. In this configuration, the detector is essentially functioning as a specific photoionization detector for selective determination of aliphatics, aromatics, and amines, as well as other species. Since there is no lamp or window, sensitivity will not change with time.

## Safety Notes and Information

### Symbols



#### HIGH VOLTAGE

Voltages presenting the risk of electric shock are present in several places in the equipment. Avoid contact with hazardous live parts. Do not probe into openings or attempt to defeat safety mechanisms.



#### HOT SURFACE

The surface of the detector body may be hot while in operation (possibly in excess of 250°C). Caution should be observed.



#### ATTENTION

Refer to the manual.



#### PROTECTIVE EARTH

This internal connection provides protection against electric shock from mains voltages and should not be removed.

### Installation Category

This equipment has been designed for installation category (overvoltage category) II, pollution degree 2. It has been approved for use in heavy industrial environments. It has been tested to EN Class A limits and may not be used in residential environments.

### Safety

This controller has been designed and tested in accordance with the product safety standard, EN61010. It has left the factory in a safe condition. This instruction manual contains important information and warnings which must be followed by the user to insure safe operation and to retain the instrument in a safe condition. The case, chassis, and measuring terminals are connected to the protective earth contact of the mains inlet. The instrument operates with a three-conductor power cord having a protective earthing conductor and a plug with an earthing contact. The mains (line) plug shall only be inserted in a socket outlet provided with a protective earth contact. The protective action must not be negated by the use of an extension cord without a protective conductor. Use only with an approved mains supply cord having a rating of 2A, 250V, or greater. Do not use this equipment in a manner not specified herein.



**CAUTION: During normal operation, the detector produces ultraviolet energy (UVA, UVB), some of which may be emitted. Do not watch the arc without eye protection.**

---

### Maintenance

The exterior of the instrument should be cleaned regularly with a dusting brush. If necessary, the casing can be cleaned with a moistened cloth (99% water + 1% mild detergent). Spirit or petroleum ether can be used to remove greasy dirt. Any other cleaning agents can attack the plastic and painted surfaces.

Under no circumstances should the cleaning fluid get into the instrument. Petroleum ether is flammable, and care should be taken in its use. Under no circumstances should the detector be disassembled for cleaning. The components of the detector are assembled with special tooling and held under considerable force. Disassembly of the detector may present a safety hazard and will result in its destruction.

## Components of the Detector System

Components of the detector system are listed in **Table 1**. Check the contents of the packages to verify that everything is present. Contact the factory if anything is missing or damaged. (NOTE: damaged shipments must remain with the original packaging for freight company inspection.)

Description	Quantity	Product number
Detector cell, PDHID	1	PD-D4-I-48
Pulse supply module	1	PD-M2
Controller unit with power cord	1	PD-C2
<i>Includes:</i> Cable, computer (unattenuated) output	1	I-23136
Cable, recorder (attenuated) output	1	I-23483
Cable, controller to pulse supply	1	I-23477
Instruction manual	1	MAN-PDD4
Fittings kit	1	PD-KIT-D4
<i>Includes:</i> 1/32" polyimide ferrule	5	ZF.5V
1/16" gold-plated ferrule	5	ZF1GP
0.25 - 0.44 mm polyimide column ferrule	5	FS.4
0.4 - 0.5 mm polyimide column ferrule	5	FS.5
1/16" union 316 SS	2	ZU1MS6
1/16" tee	1	ZT1
1/8" external to 1/16" internal adapter	2	EZR21
1/8" external to 1/16" internal reducing union	2	EZR21
1/32" external nut	1	EN.5KN
Packed column adapter	1	I-23642-D4RU
Restrictor, 30 cc/min @ 60 psi He	1	TGA-R-30F60P
Helium purifier	1	HP2

**Table 1:** Components of the D-4-I system

## Description of Controls

Controls and connectors are indicated in **Figure 2** on page 6.

### **MAINS** switch

Controls mains (line) voltage to the controller unit. When this switch is on ( | ), the unit is operational except for the pulse supply (see the next paragraph). The detector heater will operate (if connected) and high voltage is present on the bias cables.



**DISCHARGE** switch and indicator

Controls power to the pulse supply module. When the switch is on and the module is connected, high voltage is generated by the unit and is present at the detector electrodes. The indicator will not light if the detector is in the standby mode, or if the pulse supply is not connected to the controller. The indicator flashes until the discharge has been established, then glows steadily.

**TEMPERATURE** control and indicator

Sets the temperature ( $^{\circ}\text{C}$ ) of the detector heater block. The indicator is steadily on when maximum power is being applied to the heater, steadily off when no power is applied, and regularly blinking on/off when the set temperature has been established.

Note that due to the fail-safe mechanism designed into the temperature controller, the heater will not operate if mains power is applied before the heater is connected or if the detector is too cold ( $< 0^{\circ}\text{C}$ ). If the heater is disconnected with mains on, the unit must first be turned off to restore control of the heater; if the unit is operated in a very cold environment, the detector should first be gently warmed without power applied.

The fail-safe mechanism will also act under any condition resulting from loss of control (*e.g.*, over-heating, RTD failure, etc.). If proper procedures have been followed and the controller will not heat the detector, there is cause to suspect that the fail-safe mechanism has been activated. Consult the factory or an authorized representative.



**Heater control may be lost during periods of fast electrical transients. The unit will self-recover.**

**MODE** switch

Determines the operational mode of the controller and unzeroes the signal output (see discussion under ZERO push button). This switch changes the bias voltages supplied to the electrodes as required for each detection mode. In the PDHID mode the bias voltages are set at  $-200$  and the linearization circuit is inactive; in the PDECD mode the bias voltages are internally controlled and the detector output is linearized. (Note that the PD-D4-I cannot operate in the PDECD mode.)

**RANGE** switch

Determines the full-scale range of the electrometer:  $100\text{ nA @ }1\text{X}$ , or  $10\text{ nA @ }10\text{X}$ . In PDECD mode, the high detector background current normally restricts operation to the  $1\text{X}$  range.

**CURRENT** switch (*Not used with the D4-I*)

Sets the standing current in PDECD mode. Pressing at the top increases the current, pressing at the bottom decreases the current.

**ATTENUATION** control

Determines the attenuation factor for the recorder output.

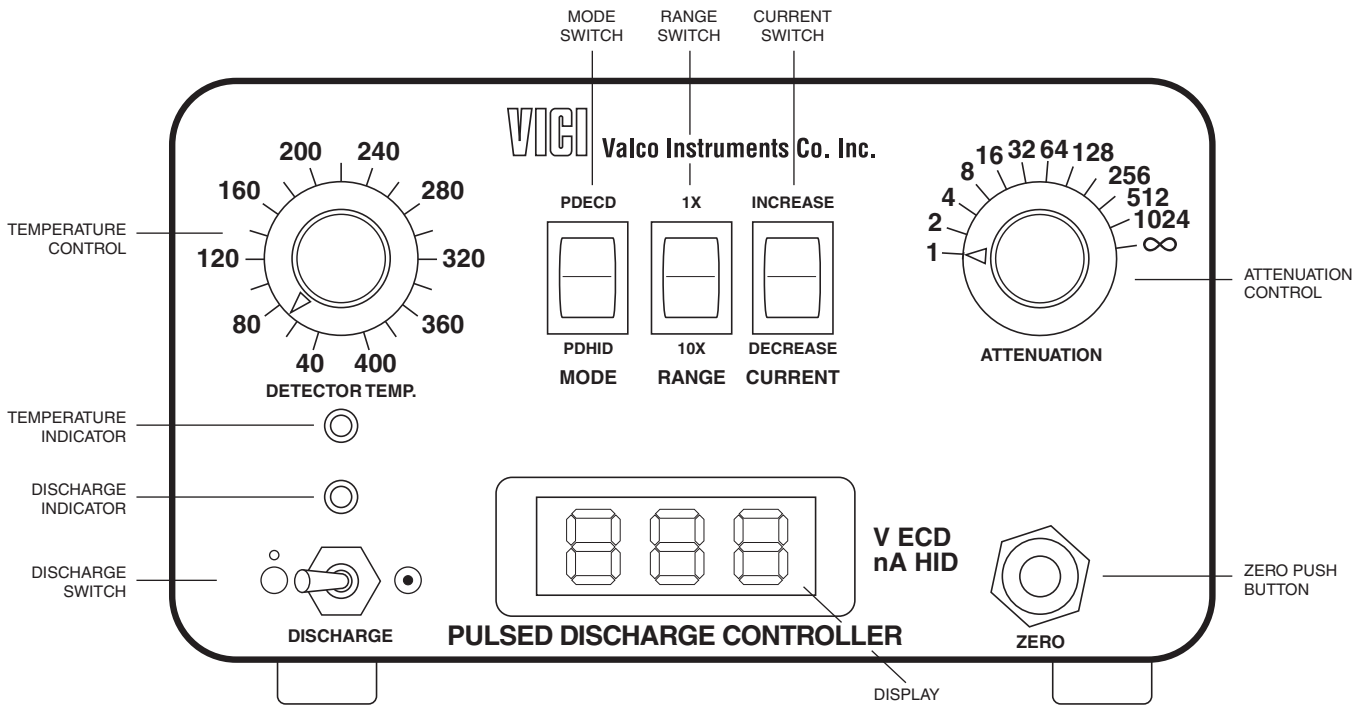

If your controller rear panel does not look like this, refer to the Appendix on page 23.

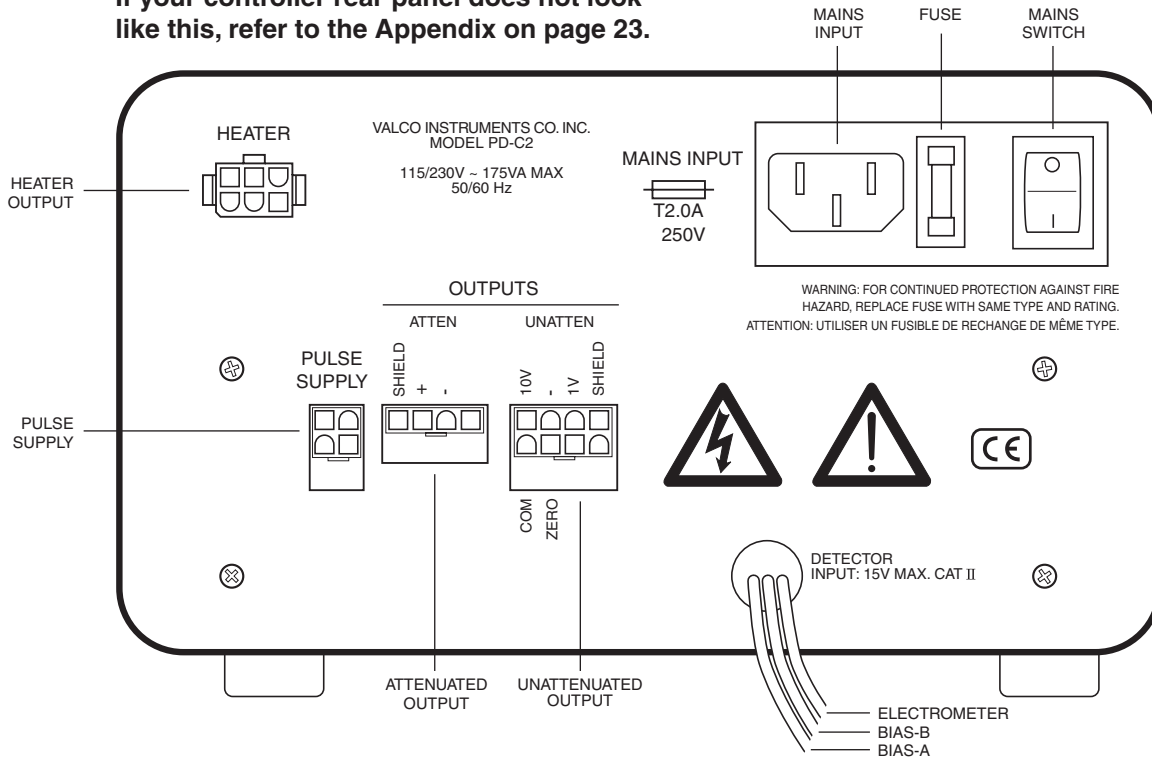

Figure 2: Controls and connections on front (top) and rear panels of the control module

**ZERO** push button

Offsets the output signal to zero volts by a measurement of the standing current. The offset is applied to the output when the button is released. Once set, the offset is not changed unless the unit is re-zeroed or the mode is changed. To remove any applied offset and restore the unit to an un-zeroed condition, toggle the **MODE** or **RANGE** switch. The function of this control is duplicated by an external logic connection; see **UNATTENUATED OUTPUT** below.

**Display**

Indicates standing current in the PDHID mode or bias voltage in the PDECD mode, auto-scaled to the most suitable range. In the un-zeroed PDHID mode, the display indicates the instantaneous signal current in nA. After zeroing, the display indicates the standing current by which the signal is offset. In the PDECD mode, the display indicates the controlling bias voltage unless the **CURRENT** switch or **ZERO** button is pressed, when it indicates the set current.

**ATTENUATED OUTPUT** connector

Normally connected to a strip chart recorder. This output has an unattenuated range of 0 - 10V, and an internal signal reference (-) at zero volts. For best noise performance, the shield (earth) and signal reference (-) should not be connected together. The signal from this output is scaled by the attenuation factor set on the front panel.

**UNATTENUATED OUTPUT** connector

Normally connected to a data acquisition system or other recording means. For convenience, a full-scale 0 - 10V output and a 1/10 scale 0 - 1V output are provided, with an internal signal reference (-) at zero volts. For best noise performance, the shield (earth) and signal reference (-) should not be connected together. The internal impedance of these outputs is 1000 ohms. The connection marked **ZERO** is a low-true, 5V logic-level input which duplicates the function of the front-panel **ZERO**; connection of this input to COM through either a relay contact or logic gate is equivalent to pressing the **ZERO** button.

**HEATER OUTPUT** connector

For connection to the detector heating system.

**ELECTROMETER INPUT** cable

For connection to the collector electrode of the PD detector. The full-scale input current is determined by the **RANGE** switch. Input voltages in excess of 15 VDC may result in damage to the electrometer.

**BIAS A, B OUTPUT** cables

For connection only to the bias electrodes of the PD detector in the manner described on page 16 under the heading "Electrical Connections". These outputs supply high voltages when power is applied to the unit, and caution should be observed when connecting or disconnecting these cables.



**NOTE: These terminals are for connection only to equipment having no accessible live parts. Insulation of external circuits to which these are connected must meet the requirements of EN61010 for 220 VDC working voltage.**

---

## Specifications

Mains (line):	115/230 V~50/60 Hz, 175 VA
Fuse:	2 A, time-delay, 5 x 20 mm
Pressure:	6.9 kPa (1 psi) operating, 6.9 MPa (1000 psi) max. working
Maximum temperature	400°C
Heater power:	60 W max., 48 V, PWM
Sensitivity	
10X range:	1.0 V/nA
1X range:	0.1 V/nA ± 1%*
Range	
10X:	10 nA full-scale
1X:	100 nA full-scale*
Noise	
1X:	20 fA/√Hz (referred to the input), 0.1 - 10 Hz*
10X:	5 fA/√Hz (referred to the input), 0.1 - 10 Hz
Risetime:	10 msec, 10% = 90%*
Output impedance:	< 1 Ω, attenuated 1 KΩ, unattenuated, 1 V, 10 V
Environmental ratings:	10°C - 50°C, 10% - 95% relative humidity

\*Controller only, PDHID mode, 10 V unattenuated output

## System Requirements

### Components Not Included with the Detector System

- Helium (99.999% purity) and other support gases
- Ultra high purity grade gas pressure regulator with stainless steel diaphragm
- Any special adapters required for connection to the gas regulator
- SS tubing to go from gas supply to GC
- Flow measuring device

### System Purity

#### Discharge/Carrier Gas Considerations

The performance of the detector is adversely affected by the presence of any impurities in the gas streams (carrier, discharge, or dopant). We recommend that a quality grade of helium 5.0 (99.999% pure or better) be used at all times. Major gas suppliers offer research grade helium (99.9999% pure) which is particularly low in fixed gas impurities and should give good results in a clean system, but even the highest quality carrier gas may contain some water vapor and fixed gas impurities; hence a helium purifier is included as part of the detector system. *The discharge gas must **always** flow through the helium purifier.*

Whenever a new batch of discharge gas is received, we recommend performing a blank GC analysis of the gas in the PDHID mode to detect and identify the presence of any impurities. Gas purity requirements are specified on the next page.

#### Tubing

Standards of cleanliness that are suitable for many GC applications may be totally inadequate for the sensitive PDHID/PDPID work. All surfaces that contact the gas stream must be fused silica or stainless steel. Do not use copper tubing or brass fittings. All tubes must be thoroughly cleaned and baked before use.

#### Flow Controllers

The use of valves or flow controllers in which the gas stream is exposed to any polymer-based packing or lubricating material is to be particularly avoided.

#### Pressure Regulators

We recommend commercial “ultra-pure” grade regulators with stainless steel diaphragms. Regulators with diaphragms made of neoprene or other elastomers should never be used.

## Gas Specifications

	Detector Mode			
	PDHID	Ar-PDPID	Kr-PDPID	Xe-PDPID
<b>Discharge gas</b>	Helium	2% Ar in He	1.5% Kr in He	0.8% Xe in He
<b>Carrier gas</b>	Helium	*	**	**

\* Any gas including He which has an ionization potential greater than 12 eV

\*\* Any gas including He which has an ionization potential greater than 11 eV

## Purity Specifications

- Helium (discharge and carrier gas) must have a minimum purity of 99.999%, with < 20 ppm Ne impurity. For trace analysis of fixed gases, we strongly recommend 99.9999% purity He with < 0.5 ppm Ne.
- Ar-PDPID mode: 2%  $\pm$  0.2% Ar in 99.999% He balance
- Kr-PDPID mode: 1.5%  $\pm$  0.1% Kr in 99.999% He balance
- Xe-PDPID mode: 0.8%  $\pm$  0.2% Xe in 99.999% He balance

# Installation

---

The detector is usually mounted on top of the GC column oven. The cabling as supplied requires the discharge module to be located within 0.6 m (2') of the detector and the controller to be within 1 m (3.5') of the detector and discharge module. The power cord for the controller is 1.8 m (6') long, and the signal output cables (attenuated and unattenuated) are 1.2 m (4') long.

## General Precautions

- Do not use plastic/polymer or copper tubes for gas handling and interconnectons. Use only stainless steel tubing with Valco gold-plated ferrules.
- Do not turn the unit on until the helium discharge gas is flowing through the detector.
- Do not shut off or disconnect the discharge gas when the detector is hot, even if the unit is turned off. Turn off both power switches (front and back of the controller) and allow the detector to cool down naturally before disconnecting or shutting off the discharge gas.
- Do not cover the unit with materials or devices which would restrict air circulation.
- Position the controller unit where the mains switch on the rear panel can be reached easily.

## Mounting the Detector on the GC

### Vertical Mounting

Most GCs have an existing opening which will allow the PDD to sit vertically on top of the column oven with the column inlet manifold extending into the oven. If you are replacing an existing detector, you can usually just remove it and set the PDD in its place. If not, use a drill or chassis punch to drill a hole of the proper size, and set the detector in position.

While trying to match the mounting holes of the base plate to every GC on the market is impractical, we have located the mounting holes so that at least two of them will coincide with existing holes on the GC. If you had to drill a new hole to mount the PDD, you will have to drill new mounting holes as well. Orient the detector to allow for easy cable and gas connections.

## Gas Connections

Remember these three points discussed earlier: (1) all surfaces that contact the gas stream must be fused silica or stainless steel; (2) do not use copper tubing or brass fittings; and (3) all tubes must be thoroughly cleaned and baked before use. The installation instructions below assume that the detector discharge gas will be supplied from a nearby cylinder of helium of the proper purity. If your installation is different, you may need to modify the instructions appropriately. A number of Valco fittings have been supplied in the fittings kit to handle different situations.

**Figure 3** illustrates gas connections for the PD-D4-I detector system. Since the distance from the helium supply to the GC varies from installation to installation, we do not supply tubing for that purpose.

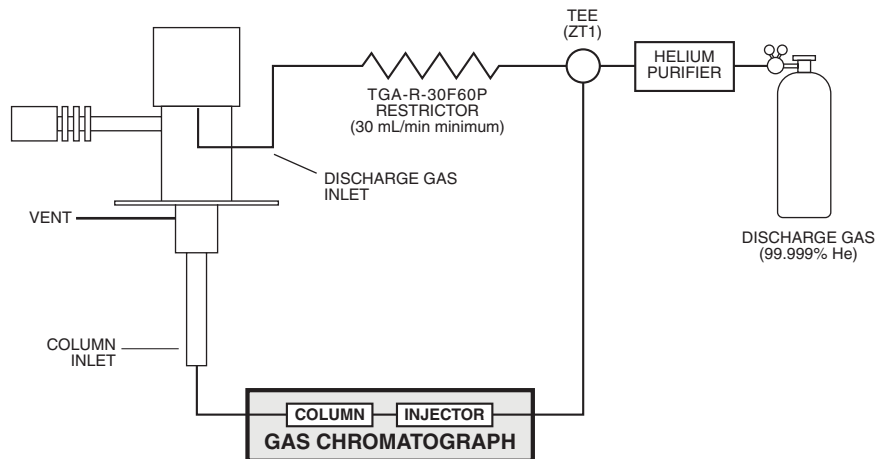

**Figure 3:** Gas connections for a PD-D4-I system

### Installing and Purging the Gas Regulator

1. Make sure the on/off valve on the helium cylinder is completely closed. Screw the CGA fitting nut of the regulator into the helium cylinder. Go beyond finger-tight, but do not tighten the nut all the way – some leakage is required for the purging operation.
2. Turn the output pressure regulating knob completely counterclockwise.
3. Open the cylinder on/off valve *slightly* and quickly close it again.
4. Adjust the tightness of the regulator connecting nut to allow a pressure reduction of ~690 kPa/sec (100 psi/sec). With a new bottle, the gauge should start out at about 14 MPa (2000 psi).
5. When the pressure drops into the 1.4 - 3.4 MPa (200 - 500 psi) range, open the cylinder on/off valve slightly and quickly close it again.
6. Repeat Step 5 eight or ten times to be certain that all the air is purged. On the final purge, tighten the regulator connecting nut very securely as the pressure approaches the 2.1 - 3.4 MPa (300 - 500 psi) range.
7. Open the cylinder valve to pressurize the regulator once again. Close the valve and observe the needle of the high pressure gauge for 15 minutes. If it doesn't move, there is no critical leak on the high pressure side of the regulator.



**CAUTION:** Never use leak detecting fluids on any part of this system.





### Installing and Purging the Helium Purifier

1. If the pressure regulator has a 1/8" *male* cone-type outlet port, install the Valco 1/8" external to 1/16" internal reducer (EZR21); if it has a 1/4" *male* cone-type outlet port, install the Valco 1/4" external to 1/16" internal reducer (EZR41). For other regulator outlet fittings, a wide variety of Valco adapters is available.
2. Remove the cap from the inlet tube of the Valco helium purifier and insert the tube fitting into the 1/16" reducer port. (Keep the outlet tube capped.) Use a 1/4" wrench to turn the nut one-quarter turn past the point where the ferrule first starts to grab the tubing. Do not remove the fitting. When made up properly, it should be leak-tight.
3. Turn the output pressure regulating knob clockwise until the gauge registers 345 KPA (50 psi).
4. Allow five minutes for equilibration, then turn the regulating knob all the way counterclockwise.
5. Observe the needle of the output pressure gauge for 15 minutes. There will be a slight initial drop, but if it doesn't move after that, consider that all the connections are tight.
6. If necessary, use an electronic leak detector to locate any leaks. If a leak detector is not available, tighten all the fittings (including the output pressure gauge), and repressurize the system for another test.



**CAUTION: Never use leak detecting fluids on any part of this system.**

7. Upcap the outlet tube of the purifier and purge the system for 15 to 30 minutes at 60 - 80 mL/min to eliminate air from the purifier getter material.

### Connecting the Discharge Gas to the Detector

1. If you are supplying the GC from the helium purifier, use the Valco tee (ZT1). Otherwise, use one of the Valco 1/16" unions (ZU1) to connect the outlet tube of the purifier to the inlet of the supplied discharge gas restrictor (TGA-R-30F60P).
2. Connect the outlet end of the restrictor to a flow measuring device and adjust the helium pressure to obtain a flow of ~30 mL/min.
3. After setting the flow rate, connect the outlet of the restrictor to the discharge gas inlet tube at the top of the detector.

## Capillary Column Connection

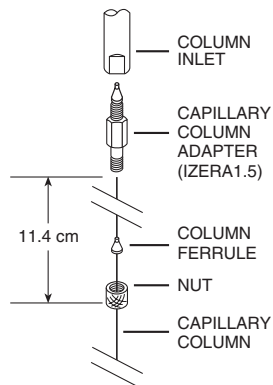

### ***If the capillary column adapter is installed in the column inlet:***

1. Make a mark on the column 11.4 cm from the end.
2. Remove the knurled nut and plug from the capillary column adapter in the column inlet at the bottom of the detector. Slide the nut over the end of the column, followed by the appropriate column ferrule (FS.4 or FS.5, or ZF.5V for megabore).
3. Seat the ferrule in the detail of the column adapter and begin sliding the column through the capillary column adapter and into the column inlet.
4. Get the nut started on the threads and tighten it until you feel it contact the ferrule, then back off half a turn. Slide the column into the column inlet until the mark is flush with the surface of the knurled nut, and secure the column in the adapter by tightening the knurled nut *finger tight only*.

### ***If the capillary column adapter has been removed, reinstall it:***

1. Unscrew the liner as far as it will go, then screw the fitting body into the column inlet fingertight.
2. While using a 1/8" wrench to prevent rotation of the liner (the part with the seat for the column ferrule), use a 1/4" wrench to tighten the body of the adapter until the ferrule has sealed. The liner *will deform* if it rotates.
3. Proceed to Step 1 above.

## Packed Column Connection



**To prevent detector contamination, we strongly recommend disconnecting the column from the detector during column bakeout procedures.**

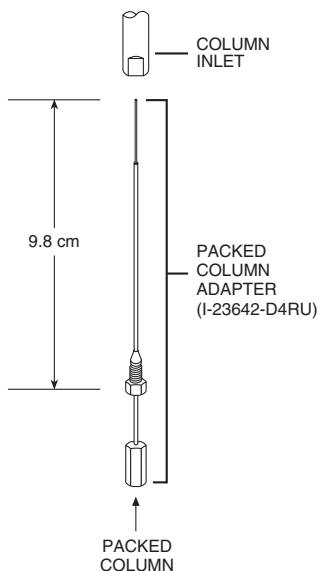

The D4 is optimized for packed columns. The column tubing must be thoroughly cleaned and baked before the column is packed. Even when the best care is taken in column tubing cleaning and in the support and stationary phase selection, a new column will often bleed compounds, resulting in a considerable increase in the detector baseline. This initial bleed will usually be reduced to acceptable levels after the column is conditioned with clean carrier gas flow for several hours at the recommended bakeout temperature.

1. Loosen and remove the knurled nut and plug of the capillary column adapter, (or remove the column ferrule and the column if one has been installed).
2. Use a 1/8" wrench to hold the liner – that part of the adapter in which the column ferrule sits. While the 1/8" wrench keeps the liner from rotating, use a 1/4" wrench on the fitting body to loosen the adapter 1/2 turn.

3. Set aside the 1/8" wrench and completely remove the adapter from the column inlet.
4. Screw the packed column adapter into the column inlet by hand. *Exercise caution*, as the tip of the adapter is very fragile. Then tighten the adapter with a 1/4" wrench, using an additional wrench on the flats of the column inlet to support the detector.
5. Connect the 1/8" column to the packed column adapter with the EZRU21 reducing union supplied in the fittings kit.

## Testing for Leaks

It is critical for the system to be leak-tight, and an additional check at this point can save many headaches later on. To test for leaks:

1. Cap the tube and pressurize the entire system with helium to 138 kPa (20 psi).
2. If the system does not hold pressure, check all the fittings with an electronic helium leak detector. **DO NOT** use leak detecting liquids.
3. Tighten fittings as required.

## Electrical Connections



**CAUTION: Do not use a wrench to tighten the SMC connectors on the bias and electrometer cables. Connections should be finger tight only.**

1. Referring to **Figure 4** as necessary, connect **BIAS-B** cable to the top electrode and the electrometer cable (**ELECT**) to the bottom electrode. The **BIAS-A** remains disconnected.
2. Connect the high-voltage cable from the detector to the pulse supply, and connect the pulse supply cable between the back of the controller and the pulse supply. Connect the heater cable from the detector to the back of the controller.

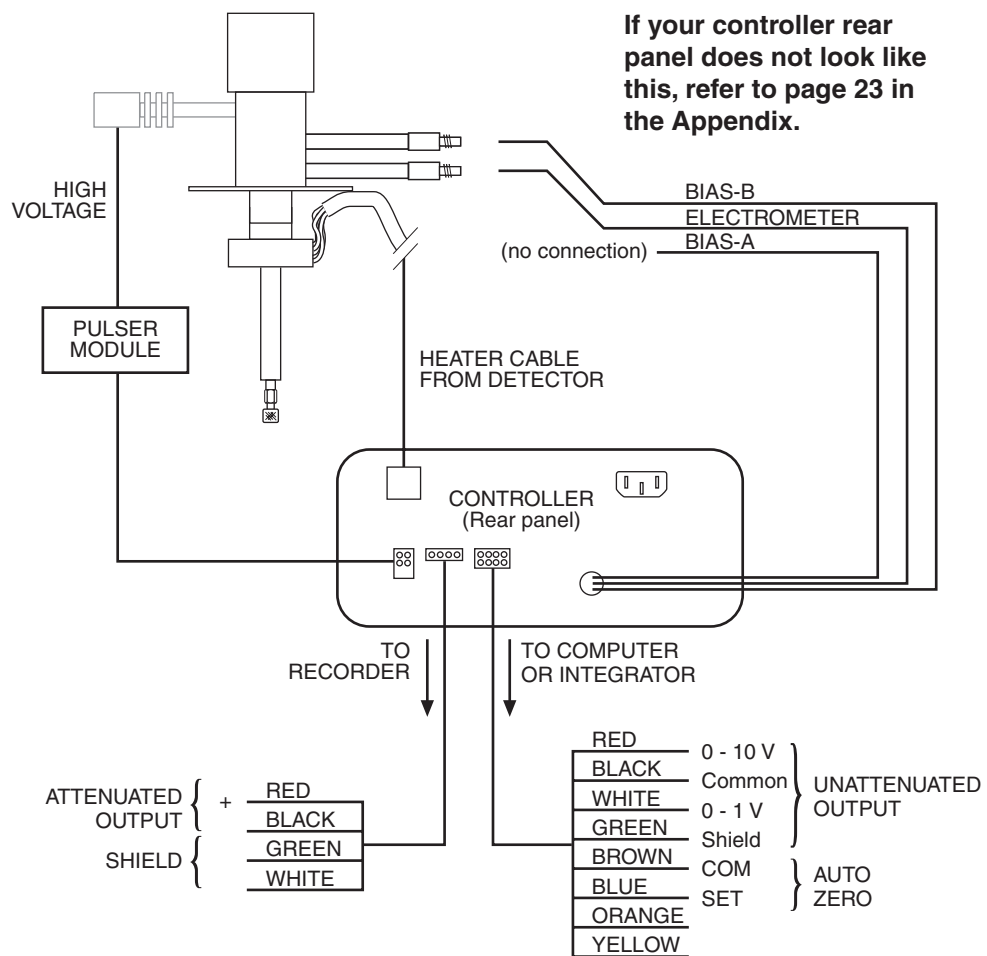

**Figure 4:** Electrical connections

## Initial Power-Up

1. Set the **MODE** switch on the front of the controller to **PDHID**.
2. Set the discharge gas flow as specified in on page 13 in the section entitled “Connecting the Discharge Gas to the Detector”.



**CAUTION:** Always make sure that discharge gas is flowing before powering up the detector.

3. Apply power to the helium purifier.
4. Turn on the **MAINS** switch located on the back of the controller and the **DISCHARGE** switch on the front of the controller. The discharge should start within five minutes. (Once a system has been up and running, the discharge will start within a few seconds.) In a clean system the discharge will have a peach/pink color. A purple discharge is an indication of impurities and/or leaks in the discharge gas stream.
5. Set the detector temperature with the **TEMPERATURE** control knob.
6. Check the detector standing/background current, which is indicated in the LED **DISPLAY** on the controller. The optimum detector background current is in the range of 1.0 to 2.5 nA. The initial value may be higher, but as the detector bakes out at its operating temperature, the background current should decrease to the optimum value.

If the standing current reaches an acceptable level, the detector is ready for use. Proceed to page 18 – “Mode Selection and Setup”.

## Troubleshooting High Background Current

If the background current does not drop below 2.5 nA even after a 12 hour bakeout, there is either a leak in the system or the column effluent is not clean. To see if the high background current is due to the column:

1. Make sure the controller is in the un-zeroed condition. (Refer to the discussion about the ZERO push button on page 7.)
2. With a capillary column, loosen the knurled nut and pull the column out ~20 mm. Secure the nut.

With a packed column, completely disconnect the column from the column inlet tube, leaving the inlet open.

3. Watch the detector standing/background current, indicated in the controller **DISPLAY**. If the current *remains high*, then either the system has a leak in the discharge gas supply line or the discharge gas has impurities in it. Proceed to the next section, “Checking for Leaks in the Discharge Gas Plumbing”. If the current *decreases dramatically*, then either the carrier gas supply has leaks and/or contaminants, or the column is the source of contamination and needs a bakeout. Read the “Column Bakeout Precautions” on the next page before proceeding.

### Checking for Leaks in the Discharge Gas Plumbing

Leaks can be detected with hydrogen. A small lecture bottle of hydrogen with a regulated flow of 10-15 mL/min through a small outlet tube is all that is required. (This method can only be used to detect leaks on the discharge gas side of the plumbing and between the column and detector inlet.)

1. Make sure the controller is in its un-zeroed condition. (Refer to the discussion about the ZERO push button on page 7.)
2. Hold the hydrogen outlet tube at a fitting connection for ten seconds while monitoring the standing current display on the controller.
3. If the current *remains the same*, proceed to the next fitting. If the current *increases*, there is a leak at that connection. Tighten the fitting and test it again, repeating as necessary until there is no change in the standing current.
4. Repeat the test for every fitting in the discharge gas plumbing.
5. Reinstall the column according to the instruction on page 14. When the standing current reaches an acceptable level, the detector is ready for use. Proceed to the next chapter, "Mode Selection and Setup". If the current stays high, use this method to check for leaks at the column/detector connection.

### Column Bakeout Precautions

To prevent detector contamination, we strongly recommend disconnecting the column from the detector during column bakeout procedures.

When the column is reinstalled after bakeout (refer to page 14 if necessary), the standing current should be at an acceptable level. If you have exhausted these troubleshooting methods and the standing current is still high, consult the factory.

---

## Mode Selection and Setup

---

### Helium Ionization Mode

If the instructions of Step 1 at the top of page 14 were properly executed, the column should already be properly positioned. Since there may be some variation in the flow rate for the different types of capillary columns, the user may want to optimize the column position within this suggested range. DO NOT insert the column more than 11 cm.

With this flow configuration, only pure helium passes through the discharge region, minimizing the chance of discharge electrode contamination through contact with the eluting sample. However, if very high concentrations of organic compounds are introduced for extended periods of time, they could diffuse into the discharge region and contaminate the electrodes. Under normal chromatographic use with capillary columns, such contamination is negligible even over extended periods.

### Selective Photoionization Mode

Since the pulsed discharge detector is essentially a windowless helium photoionization detector, changing the discharge gas from pure helium to helium doped with argon, krypton, or xenon changes the discharge emission profile. This results in a change in the photon energy due to additional resonance atomic emissions and diatomic emissions from the rare gas added. Thus a single detector can be operated in any of the three photoionization detector (PID) modes: Ar-, Kr-, or Xe-PID.

Doped helium is used rather than other pure gases in order to retain the benefits of the helium: namely, its transparency for Ar, Kr, and Xe resonance radiation and its efficient cooling of the electrodes. Any problems associated with the presence of a window between the photon source and the ionization chamber are eliminated. In most applications involving current commercial PIDs, analyte condensation and decomposition on the window attenuate the lamp energy, necessitating frequent cleaning and recalibration.

Custom gas blends for the pulsed discharge detector are available from leading gas suppliers at special prices. Alternatively, they may be formulated on the spot by using appropriate fixed restrictors to mix appropriate amounts of pure helium and pure dopant through a tee. Since all gas streams must pass through a Valco purifier, the second option requires an additional purifier for each dopant. This may still be more cost effective than requesting a custom blend of the more expensive Kr or Xe; since the typical flow rate required for the pure dopant rare gas is about 0.3 - 1 mL/min, a small lecture bottle can last for a long time. In either case, the total discharge gas flow rate should be the same as specified in "Connecting the Discharge Gas to the Detector" on page 14.

**Ar-PDPID**

Changing the discharge gas from helium to a mixture of 2% argon in helium changes the photon energy level from the 17 - 13.5 eV range to the 11.8 - 9.8 eV range. The argon emission consists of resonance radiation at 11.8 eV and 11.6 eV and the diatomic  $\text{Ar}_2$  emission in the range of 9.2 - 10.3 eV. Except for fixed gases and a few organic compounds like  $\text{CH}_4$  (IP = 12.5 eV),  $\text{CH}_3\text{CN}$  (IP = 12.2 eV) and some fluoro-chloro hydrocarbons, the majority of organic compounds have ionization potentials lower than 11.8 eV. Thus the Ar-PDPID is nearly universal, like the flame ionization detector, but without the risks associated with the presence of an open flame and hydrogen.

**Kr-PDPID**

The recommended proportion is 1.4% Kr in He as the discharge gas. The krypton emission consists principally of resonance lines at 10.6 eV and 10.1 eV. The Kr-PDPID can detect compounds with IP < 10.6 eV, which includes unsaturated and cyclic hydrocarbons, alcohols, aldehydes, organic acids, esters, etc.

**Xe-PDPID**

The recommended proportion is 0.8% Xe in He as the discharge gas. The xenon emission consists principally of resonance lines at 9.6 eV and 8.4 eV, and can detect compounds with IP < 9.6, like aromatics, ethers, alcohols, aldehydes, etc.

In addition to the specific compounds named in the three paragraphs above, certain important inorganic compounds like ammonia, hydrogen peroxide, arsenic trichloride, hydrogen sulfide, arsine, phosphine, nitric oxide, carbon disulfide etc. can be selectively detected using the appropriate photoionization mode.

Each dopant gas requires an additional helium purifier, which must be purged and conditioned in the same manner as the purifier installed on the discharge gas supply. If you are using more than one dopant, we recommend use of a Valco multiposition stream selection valve so that no fittings have to be disconnected. Not only is this convenient, it keeps the system closed, minimizing chances of contamination. When changing from one dopant to another, allow at least one hour for the old gas to be purged from the system.



## Appendix: PD-C2 Controller *(shipping February 2014)*

If you have been directed to this part of the manual, you are probably replacing an older PD-C2 controller or have received a new Pulsed Discharge Detector with the latest design. If that is the case, congratulations. You have the latest and greatest controller as a component of a truly remarkable detector system. Functionally, this controller does everything that our previous version did, but the new one does it with less power, greater efficiency, and fewer parts.

There are some minor changes to the rear panel connectors in this most recent version of the PDD controller. (**Figures 5 and 6**) The same signal outputs are provided, but they are now all accessed through one output connector.

### ATTENUATED OUTPUT

The attenuated signal is normally connected to a strip chart recorder or similar recording device. This output is designed for a 1mV full scale strip chart input. There is also an internal signal reference (-) at zero volts. For best noise performance, the shield (earth) and signal reference (-) should not be connected together. The signal from this output is scaled by the attenuation factor set on the front panel.

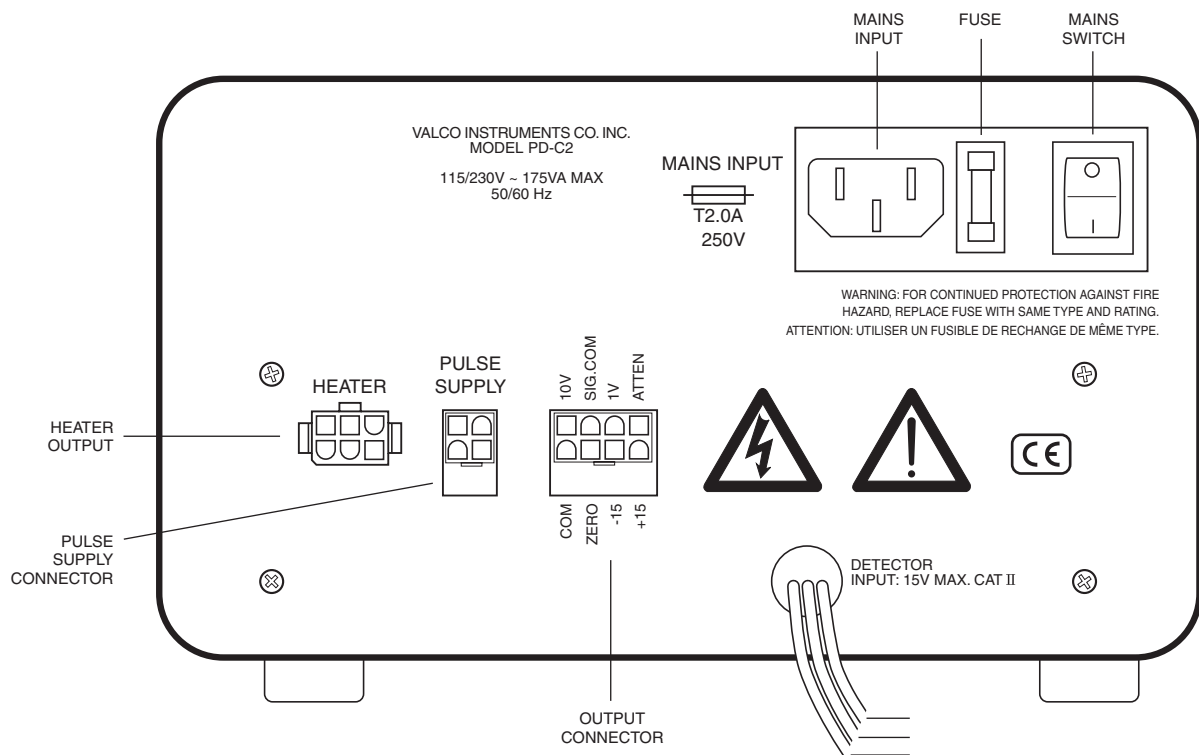

**Figure 5:** Rear panel of the control module

### UNATTENUATED OUTPUTS

Normally connected to a data acquisition system or other recording means. The two unattenuated outputs are 0 - 10V full scale and 0 - 1V full scale. Output are provided, with an internal signal reference (-) at zero volts. For best noise performance, the shield (earth) and signal reference (-) should not be connected together. The internal impedance of these outputs is 1000 ohms.

### ZERO FUNCTION

The connection marked ZERO is a low-true, 5V logic-level input which duplicates the function of the front-panel ZERO; connection of this input to COM through either a relay contact or logic gate is equivalent to pressing the ZERO button.

## Electrical Connections



**CAUTION: Do not use a wrench to tighten the SMC connectors on the bias and electrometer cables. Connections should be finger tight only.**

1. Referring to **Figure 6** as necessary, connect the bias and electrometer cables as follows: the **BIAS-B** cable to the top electrode (closest to the discharge electrodes), the electrometer cable (**ELECT**) to the middle, and the **BIAS-A** cable to the bottom electrode. This setup is the same for both detector models.

The bias outputs supply high voltages when power is applied to the unit, and caution should be observed when connecting or disconnecting these cables.

The full-scale input current of the electrometer is determined by the RANGE switch. Input voltages in excess of 15 VDC may result in damage to the electrometer.

2. Connect the high-voltage cable from the detector to the pulse supply, and connect the pulse supply cable between the back of the controller and the pulse supply.
3. Connect the heater cable from the detector to the back of the controller. This connector is identical in function to the one on previous controllers, so that detectors can interchange between revisions of controllers; however, the location has moved inline with other connectors in the newest version of the controller.

**NOTE:** These terminals are for connection only to equipment having no accessible live parts. Insulation of external circuits to which these are connected must meet the requirements of EN61010 for 220 VDC working voltage.

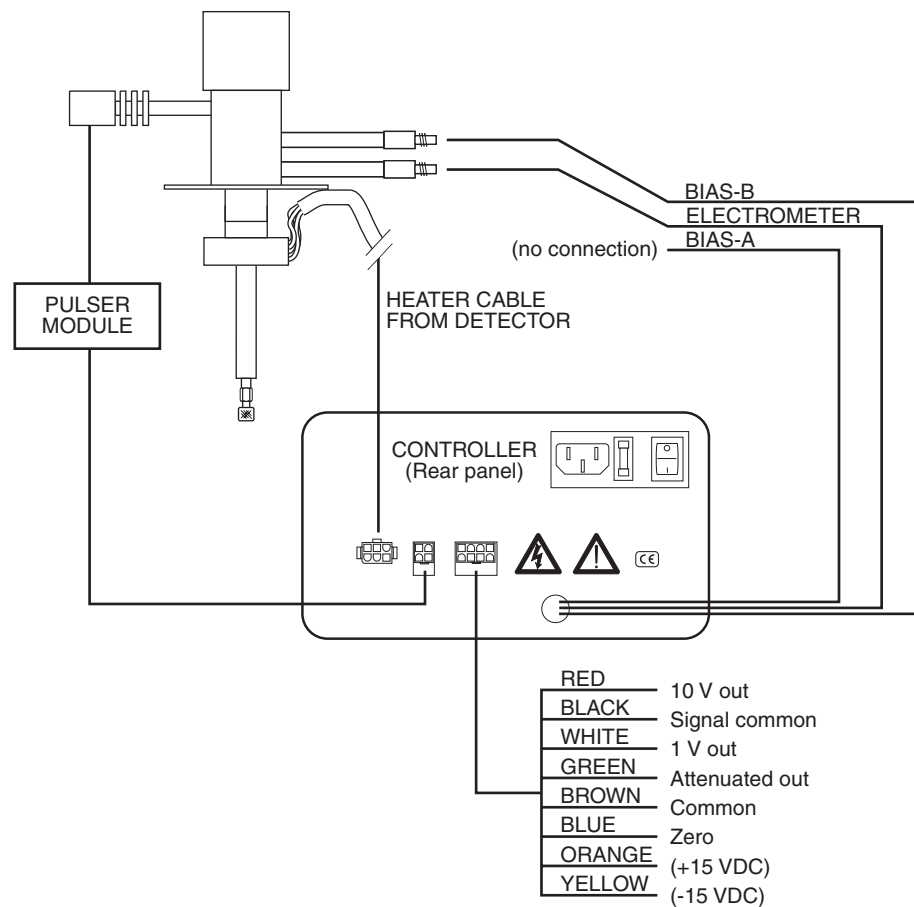

**Figure 6:** Electrical connections

## Note About Compatibility

Obsolescence planning is a significant portion of manufacturing control, as the speed at which electronic components come to market and reach end of life continues to increase. While each revision of our electronics is a reflection of newer, faster, and better components, we work very hard to ensure that the final product is completely backwards compatible. We achieved this goal with the latest updates to the pulsed discharge controller—it will work with any PDD in the field. We plan to continue support for older models for a very long time.

## Warranty

---

This Limited Warranty gives the Buyer specific legal rights, and a Buyer may also have other rights that vary from state to state. For a period of 365 calendar days from the date of shipment, Valco Instruments Company, Inc. (hereinafter Seller) warrants the goods to be free from defect in material and workmanship to the original purchaser. During the warranty period, Seller agrees to repair or replace defective and/or nonconforming goods or parts without charge for material or labor, or, at the Seller's option, demand return of the goods and tender repayment of the price. Buyer's exclusive remedy is repair or replacement of defective and nonconforming goods, or, at Seller's option, the repayment of the price.

***Seller excludes and disclaims any liability for lost profits, personal injury, interruption of service, or for consequential incidental or special damages arising out of, resulting from, or relating in any manner to these goods***

This Limited Warranty does not cover defects, damage, or nonconformity resulting from abuse, misuse, neglect, lack of reasonable care, modification, or the attachment of improper devices to the goods. This Limited Warranty does not cover expendable items. This warranty is VOID when repairs are performed by a nonauthorized service center or representative. For information about authorized service centers or representatives, write Customer Repairs, Valco Instruments Company, Inc, P.O. Box 55603, Houston, Texas 77255, or phone (713) 688-9345. At Seller's option, repairs or replacements will be made on site or at the factory. If repairs or replacements are to be made at the factory, Buyer shall return the goods prepaid and bear all the risks of loss until delivered to the factory. If Seller returns the goods, they will be delivered prepaid and Seller will bear all risks of loss until delivery to Buyer. Buyer and Seller agree that this Limited Warranty shall be governed by and construed in accordance with the laws of the State of Texas.

***The warranties contained in this agreement are in lieu of all other warranties expressed or implied, including the warranties of merchantability and fitness for a particular purpose.***

This Limited Warranty supercedes all prior proposals or representations oral or written and constitutes the entire understanding regarding the warranties made by Seller to Buyer. This Limited Warranty may not be expanded or modified except in writing signed by the parties hereto.